

CORPS

Matière aluminium
 Ra: 3.2
 Les angles doivent être cassés à 45 degrés x 1 mm
 Longueur taraudage : 20 mm mini.

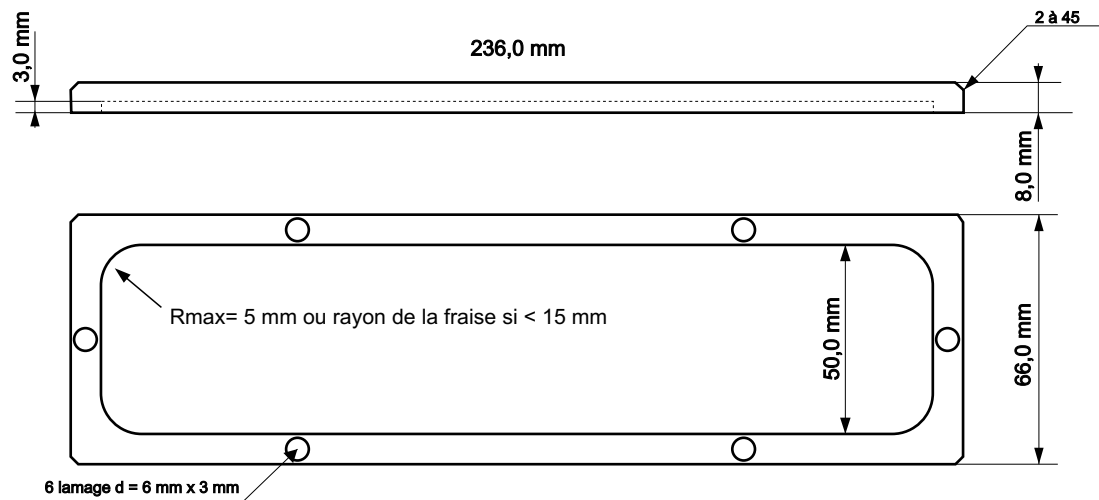
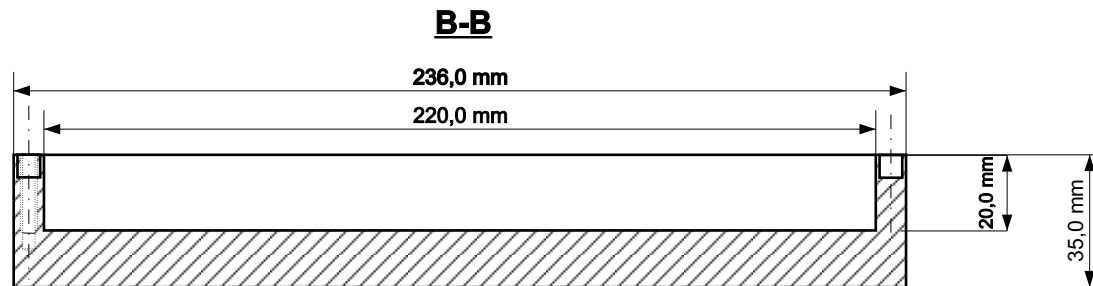

COUVERCLE

Matière : Aluminium
 Ra : 3.2
 Tolérances de fabrication : +/- 0.1 mm
 Les angles doivent être cassé à 45° x 2 mm