

6 5 4 3 2 1

D

D

Entretoise poulie

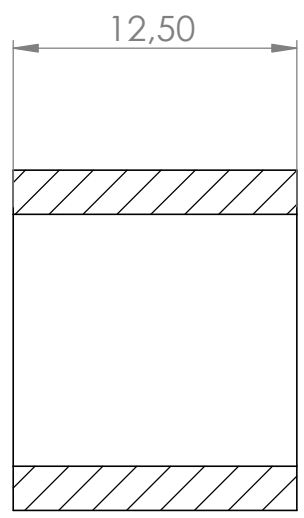
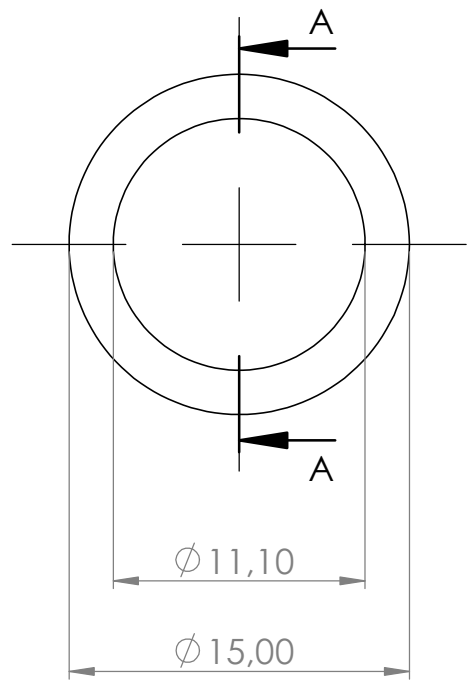

COUPE A-A

Entretoise hélice

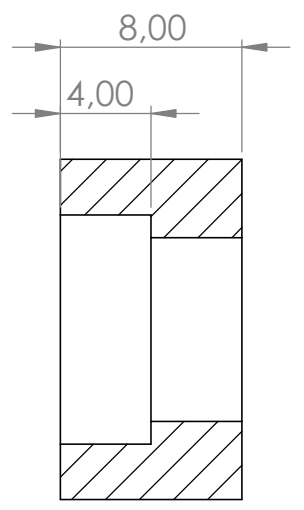
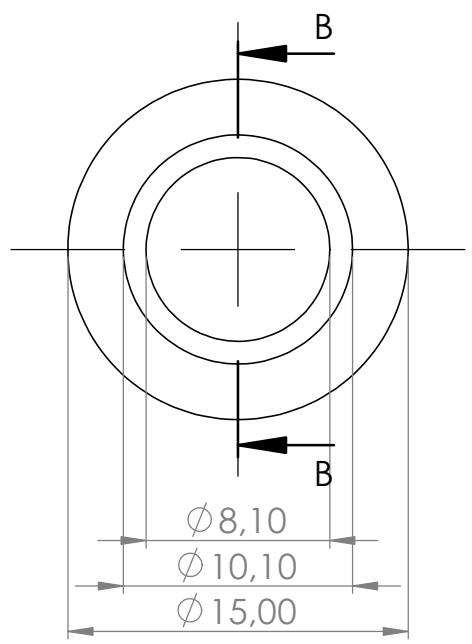

COUPE B-B

C

C

B

B

A

A

SAUF INDICATION CONTRAIRE: LES COTES SONT EN MILLIMETRES ETAT DE SURFACE: TOLERANCES : 0,1 mm				FINITION: Ra 3,2 sur les surfaces intérieures		CASSER LES ANGLES VIFS		NE PAS CHANGER L'ECHELLE		REVISION	
						TITRE: 2 entretoises en acier					
AUTEUR		SIGNATURE		DATE							
VERIF.											
APPR.											
FAB.											
QUAL.						MATERIAU: ACIER STANDARD		No. DE PLAN		A4	
								Echelle:3:1		FEUILLE 1 SUR 1	
						MASSE:					

Entretoises