

Confidential Information. Property of Merit Medical Systems, Inc.
 Reproduction or use without written consent is prohibited.

REV.		ECN:	DESCRIPTION	DATE
001		ECN_#	INITIAL RELEASE	mm/yy

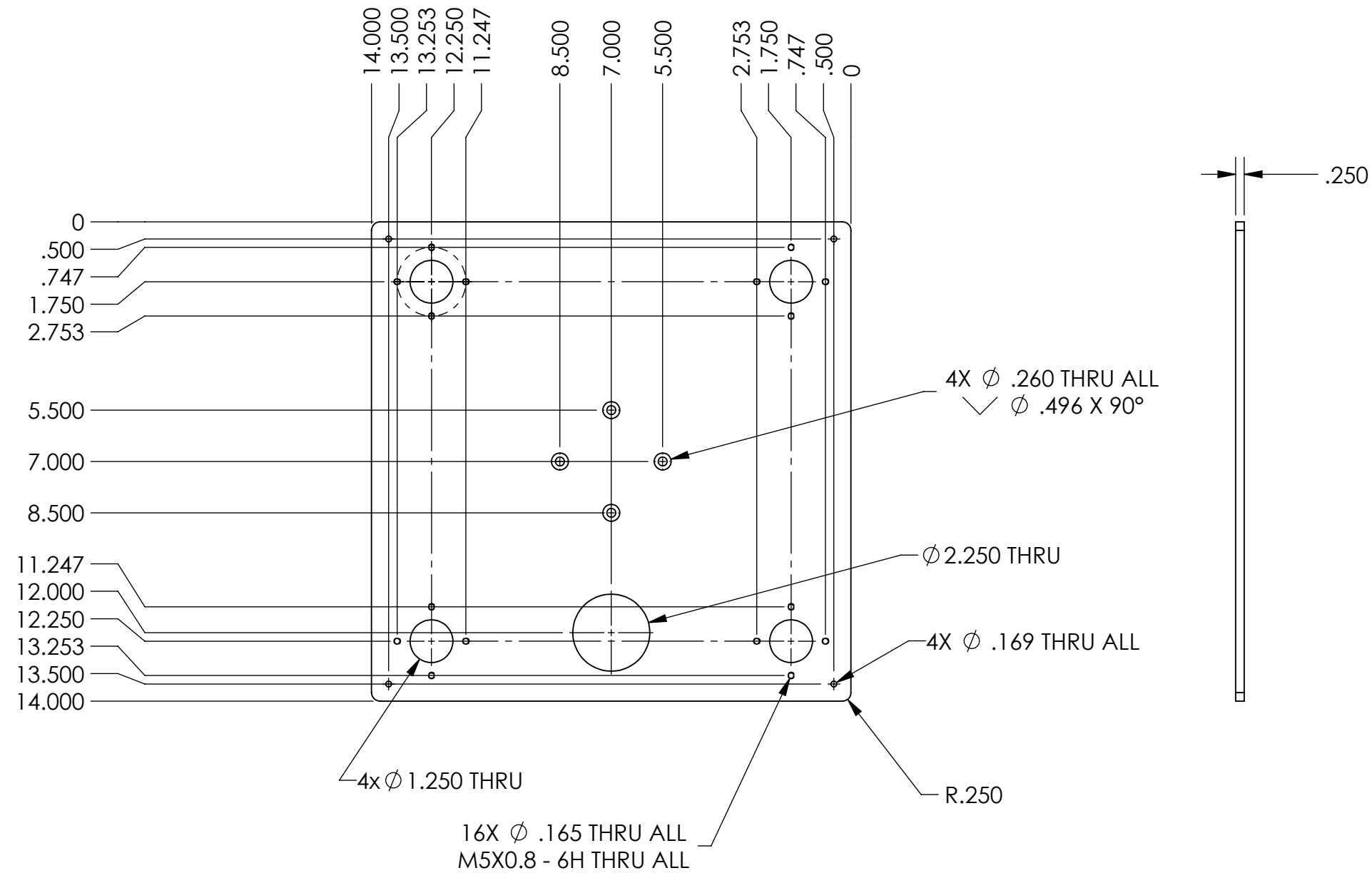

DRAWING LINKED: No
 if YES, indicate locations:

DIMENSIONS IN: INCHES/(mm)		DRAWN BY	DATE
TOLERANCES		L. Thomae	03/22/2023
Inches:	mm:	MATERIAL: 316 SS	
X.X ± 0.1	X ± 3		
X.XX ± 0.01	X.X ± 0.3		
X.XXX ± 0.005	X.XX ± 0.13		
X.XXXX ± 0.0005	X.XXX ± 0.013		
FRAC. ± 1/16	ANGLE ± 1/2°		
DO NOT SCALE BREAK ALL EDGES			



DRAWING TITLE:			
PVA Washing Machine Tank Resting Plate			
SIZE	THIRD ANGLE	DRAWING NUMBER	
B		E4334DWG001	
SCALE:	1:4	SHEET 1 OF 1	REV 001