

COUPE A-A

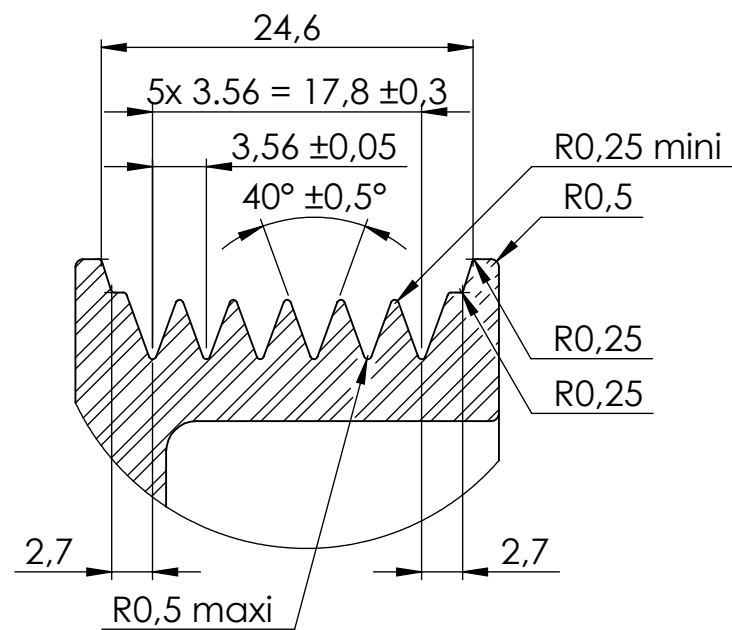
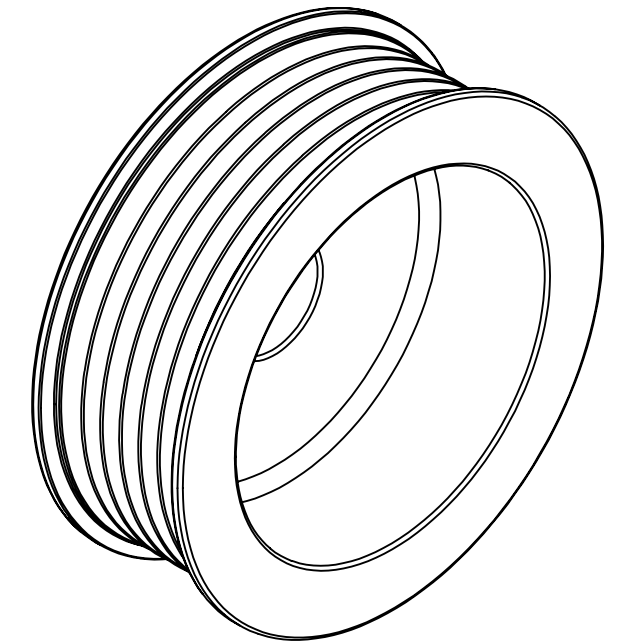

DÉTAIL B  
ECHELLE 2 : 1

Ra3.2/

1				Alu 6060	79.4x32	0.15
Qtes	REP	Valeur Unite	UNITE	DESIGNATION	DIMENSION	MASSE

**REMARQUE**

Rayons non cotés : R=0.5 maxi  
Profil de denture PK, pas = 3.56mm

Traitements : -	A3	Ech 1:1
-----------------	----	---------

Tolérances Générales ISO 2768 mK	<b>POULIE ALTERNATEUR</b>	
----------------------------------	---------------------------	--

	Date : 22/06/2021	Dessinateur : J.JAMET	<b>RR21002D</b>
--	-------------------	-----------------------	-----------------

Révision : ind.C le 04/03/24 : Matière devient Alu 6060

