

8 7 6 5 4 3 2 1

F
E
D
C
B
A

F
E
D
C
B
A

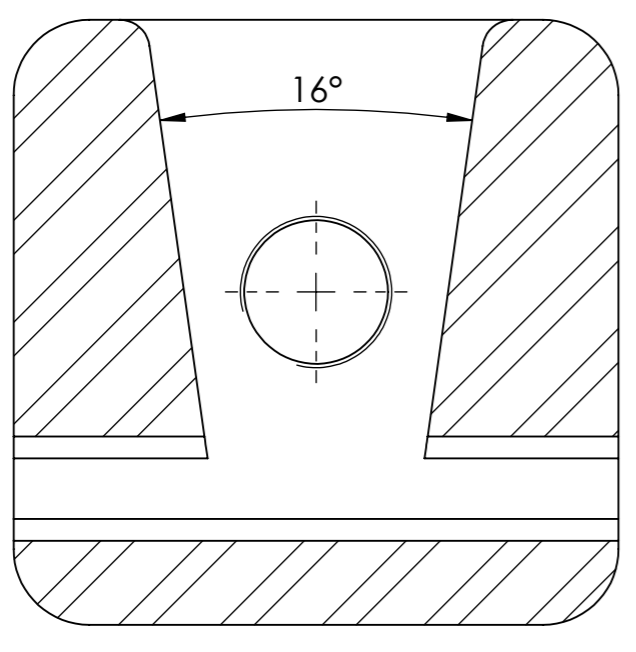
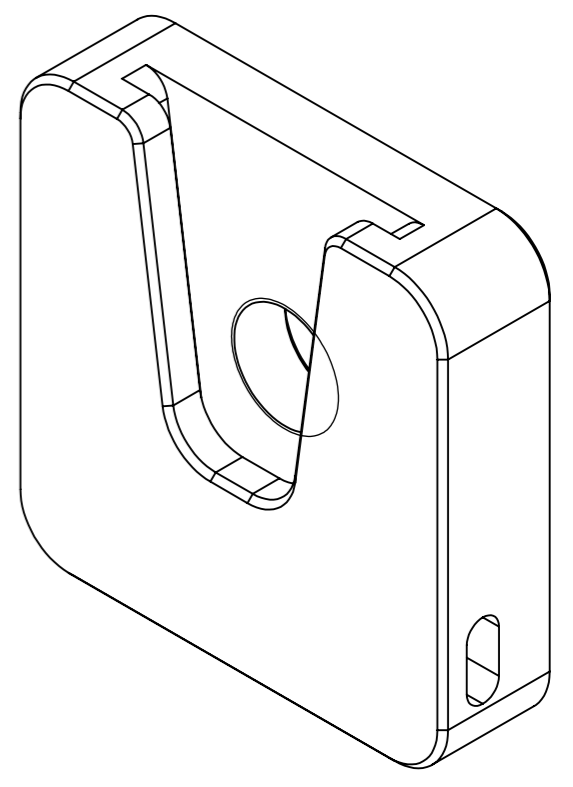
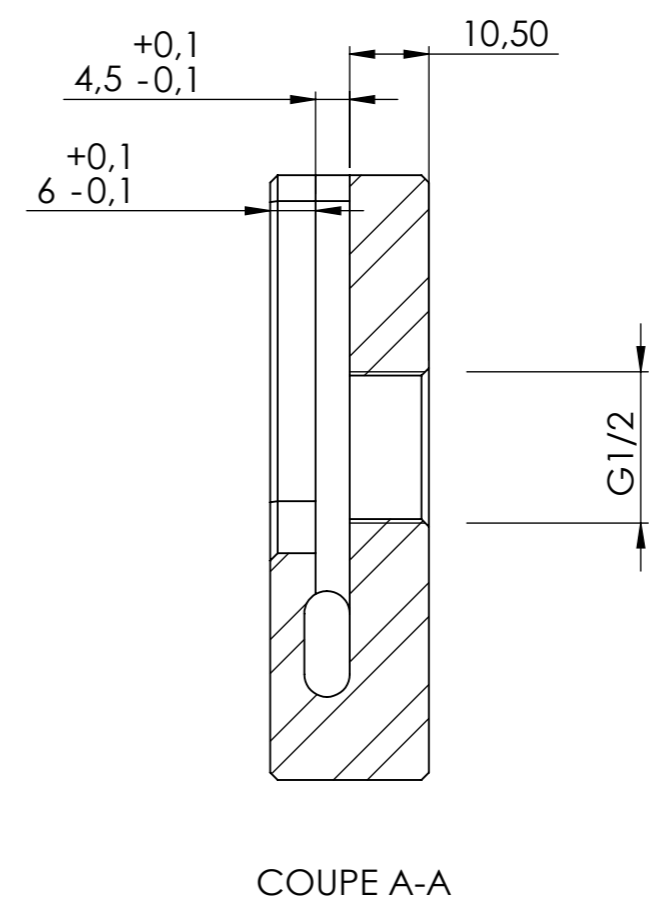
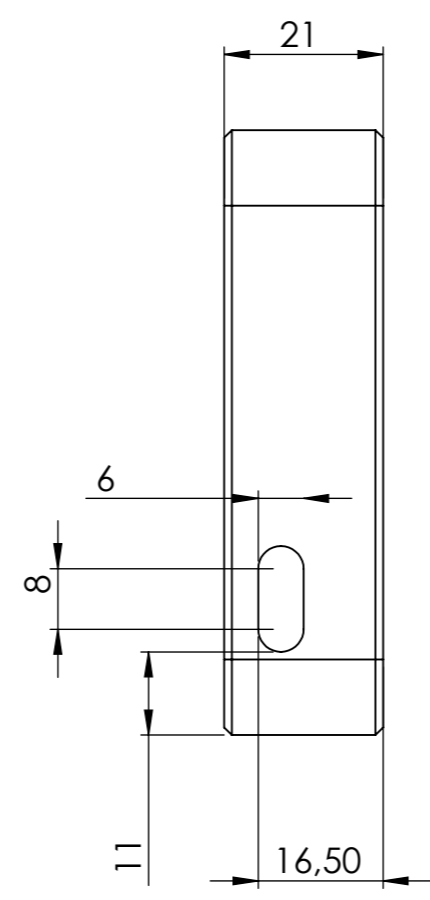
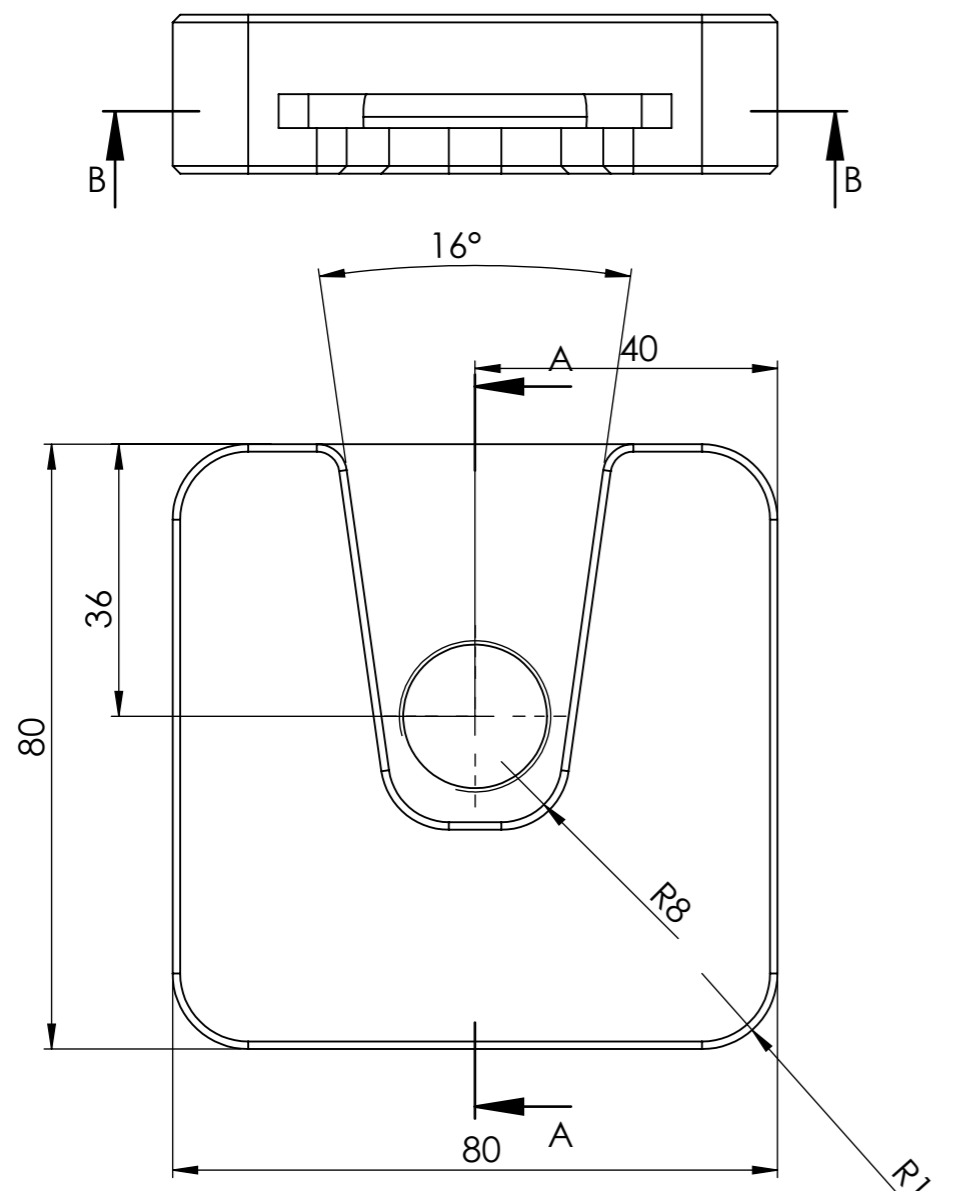

Weight		kg		Material		ACIER			
Machine		ACC		Description				adaptateur nez extrudeuse	
Projection method:		First angle		Release date		Drawing no.		Rev.	
				2024		PLATNOZ001		A	
General tolerances		ISO 2768-m		Doc. type		Part		Units unless specified	
						mm		Sheet size	
						A3		Scale	
						1:1		Sheet	
						1 / 1			

8 7 6 5 4 3 2 1