

1

2

3

4

A

A

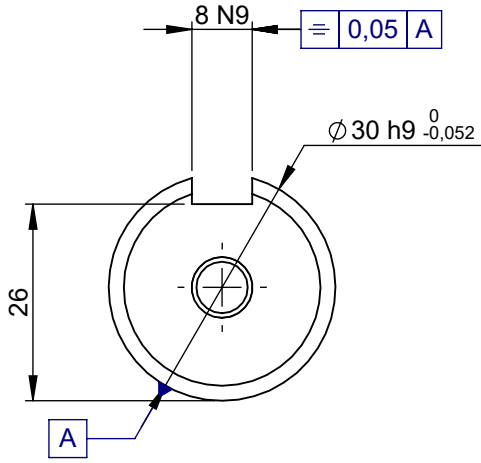

B

B

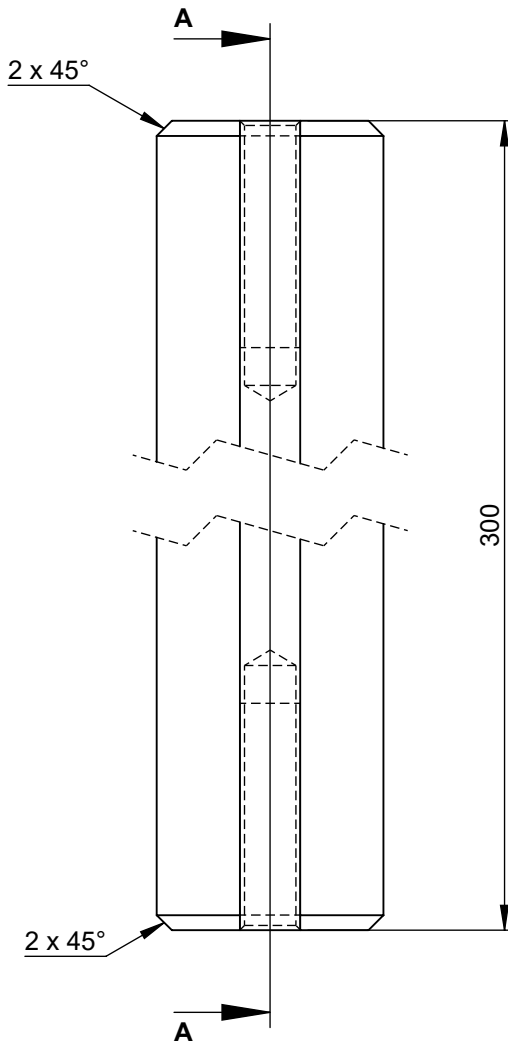

C

C

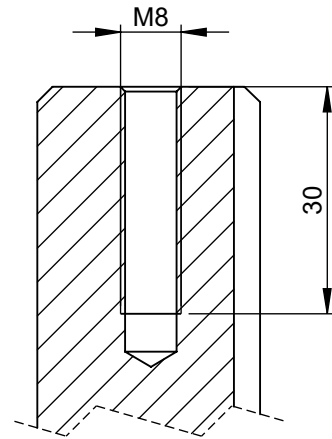

D

D

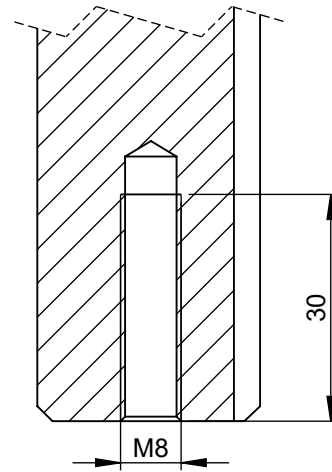

E

E

COUPE A-A

IND	ZONE	MODIFICATION	DRAWN BY	CHECKED BY	DATE
	00-	AXE 30			A4
		Treatment: AUCUN		Mass: 1,57 kg	
		Material: E335 / A60		Scale: 1:1	Sheets:1/1
		Designer: Giacalone.C	GENERAL TOLERANCE FOR MACHINING: ISO 2768-mK		
		Date: 13-05-24			
This document is the intellectual property of PELLENC and should not be copied or disclosed to any third party without our prior consent					

1

2

3

4

F

F