

8 7 6 5 4 3 2 1

F F

E E

D D

C C

B B

A A

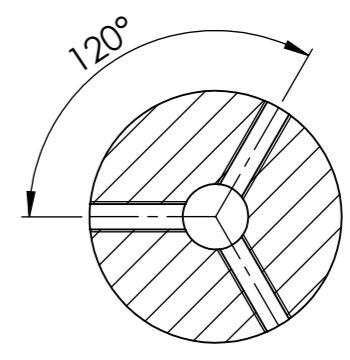
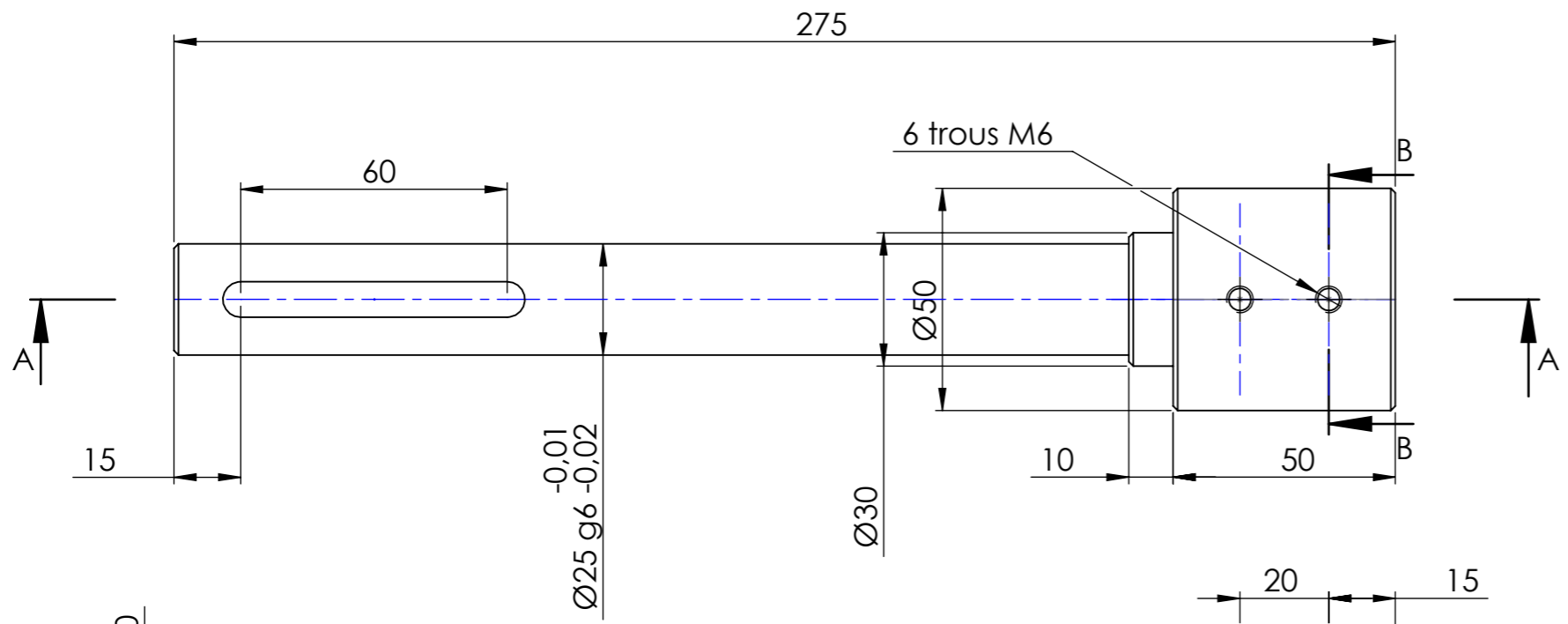

COUPE B-B
ECHELLE 2 : 3

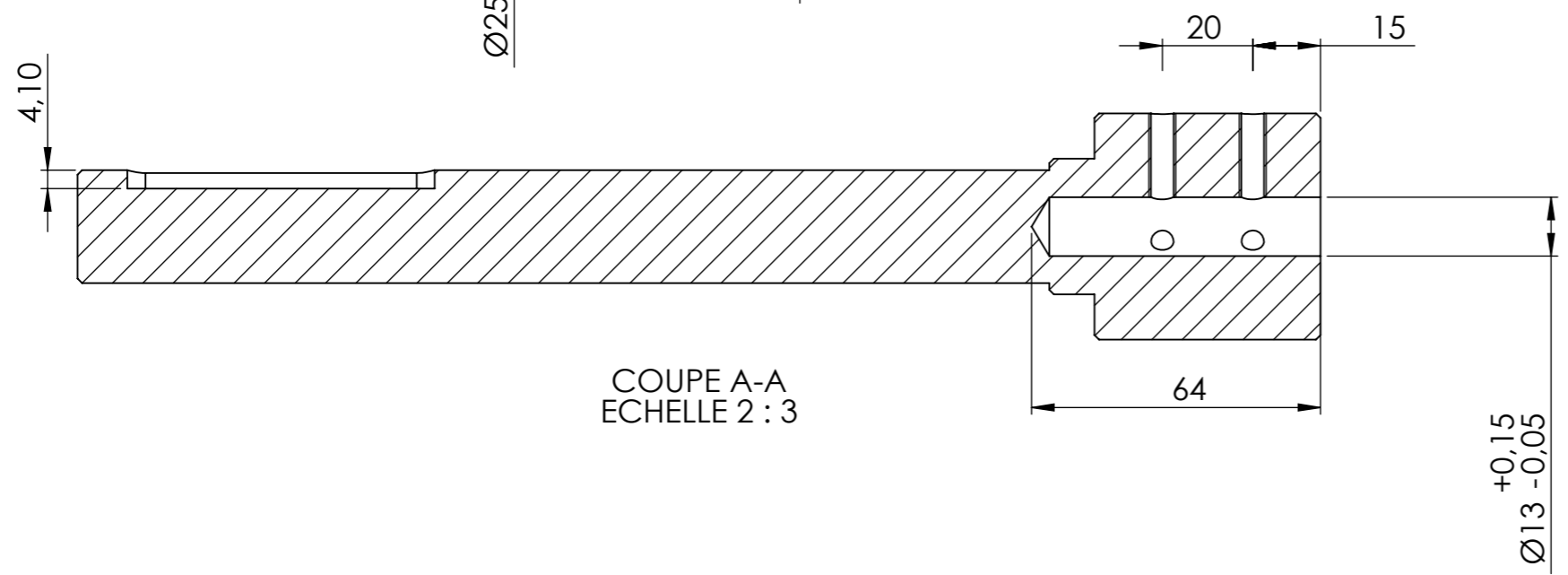

ATELIER
DES RECYCLEURS FOUS

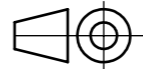
Weight		kg		Material		ACIER		
Machine		MIKKI		Description				AXE
Projection method:		First angle		Release date		Drawing no.		Rev.
				04/2022		C4PO1000		A
General tolerances		ISO 2768-m		Doc. type		Sheet size		Scale
				Part		mm A3		1:2
						Scale		Sheet
						1:2		1 / 1