

8 7 6 5 4 3 2 1

F
E
D
C
B
A

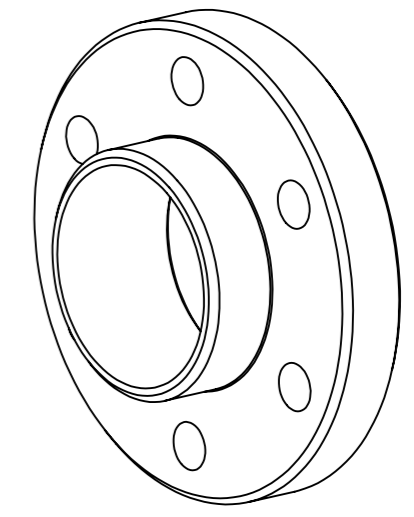
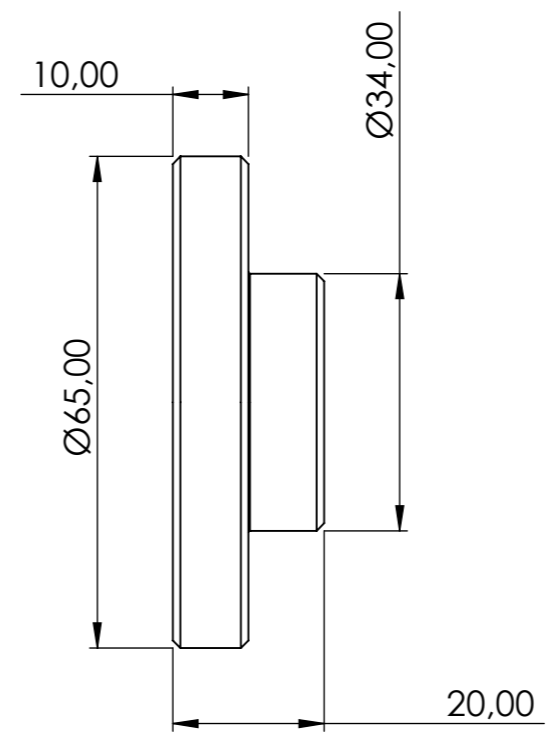
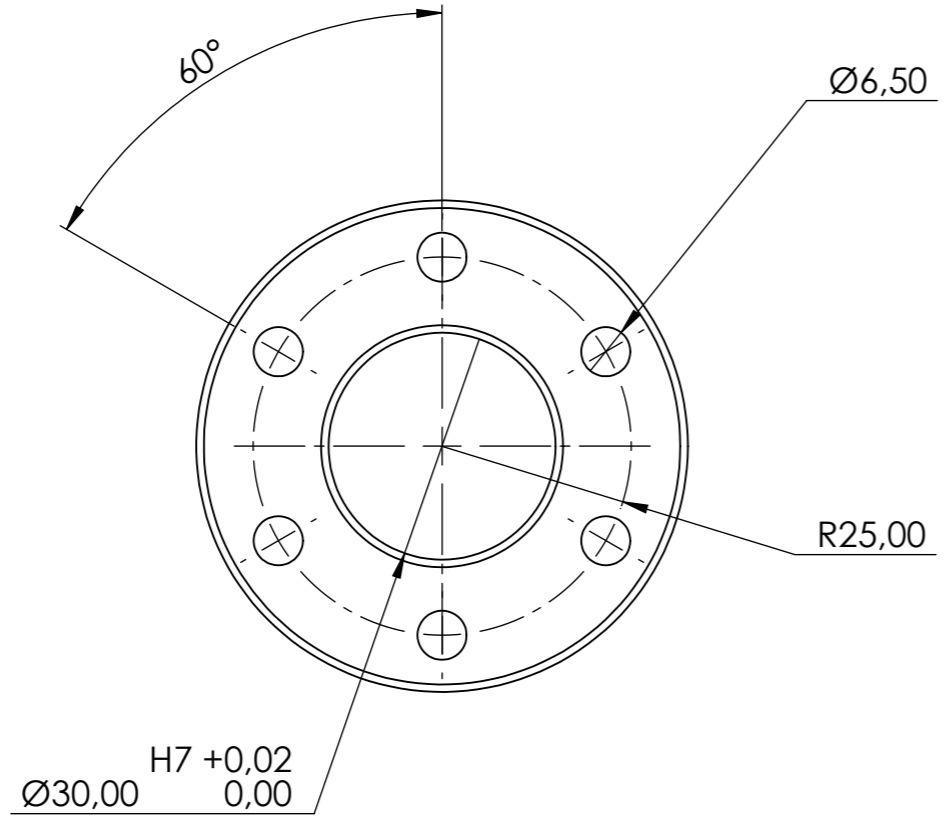
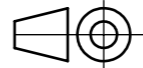

ATELIER
DES RECYCLEURS FOUS

Weight		Material			
kg		ACIER			
Machine		Description			
C4PO		BAGUE MIKKI			
Projection method:		Release date	Drawing no.		Rev.
First angle 		04/2022	C4PO1001		A
General tolerances		Doc. type	Units unless specified	Sheet size	Scale
ISO 2768-m		Part	mm	A3	1:1
					Sheet
					1 / 1

8 7 6 5 4 3 2 1

F
E
D
C
B
A