

8 7 6 5 4 3 2 1

F
E
D
C
B
A

F
E
D
C
B
A

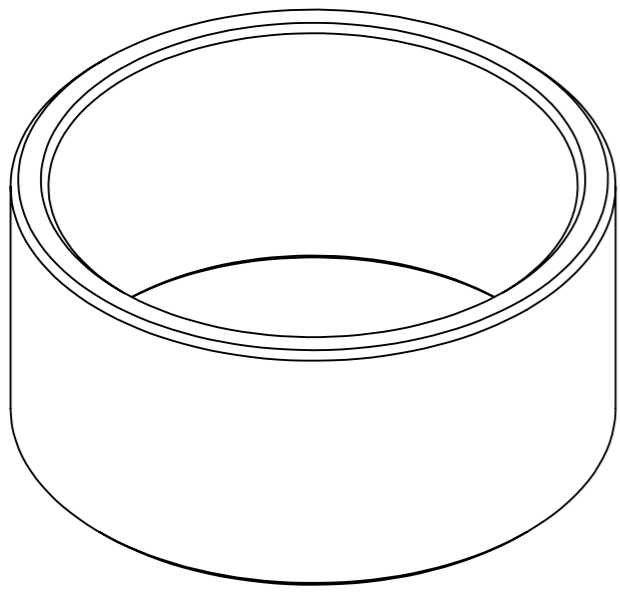
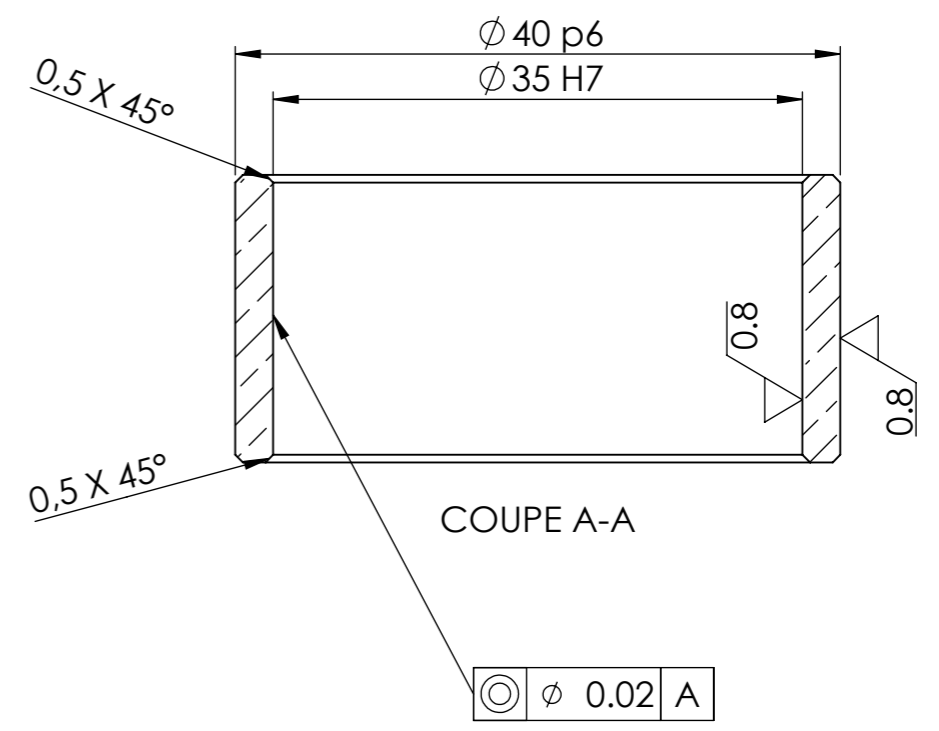
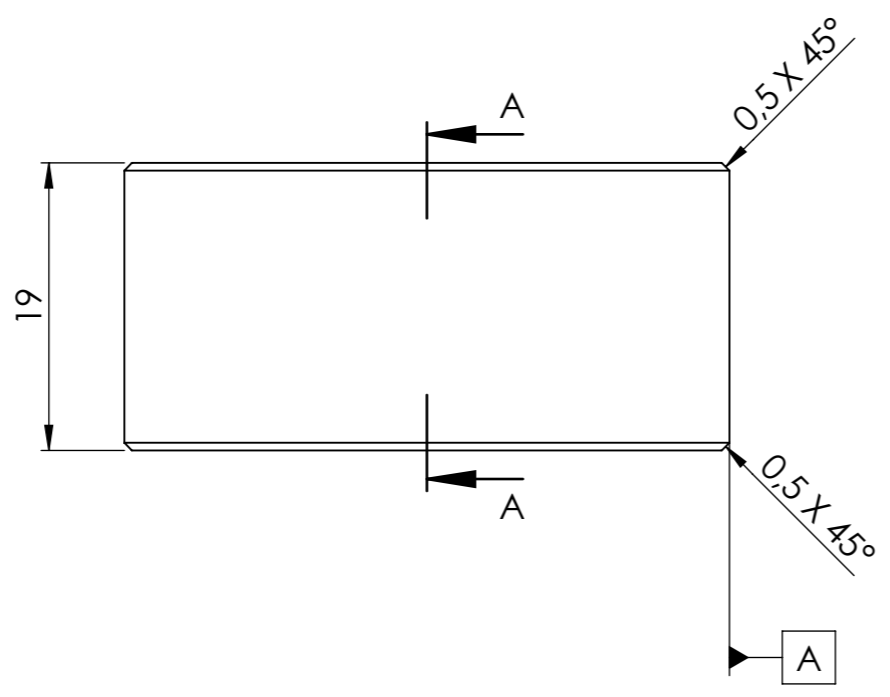

Weight	kg	Material LAITON			
Machine INJ X-WING	Description COUSSINET				
Projection method: First angle		Release date 04/2024	Drawing no. XWG0106		Rev. B
General tolerances ISO 2768-m	Doc. type Part	Units unless specified mm	Sheet size A3	Scale 2:1	Sheet 1 / 1

8 7 6 5 4 3 2 1