

8

7

6

5

4

3

2

1

F

F

E

E

D

D

C

C

B

B

A

A

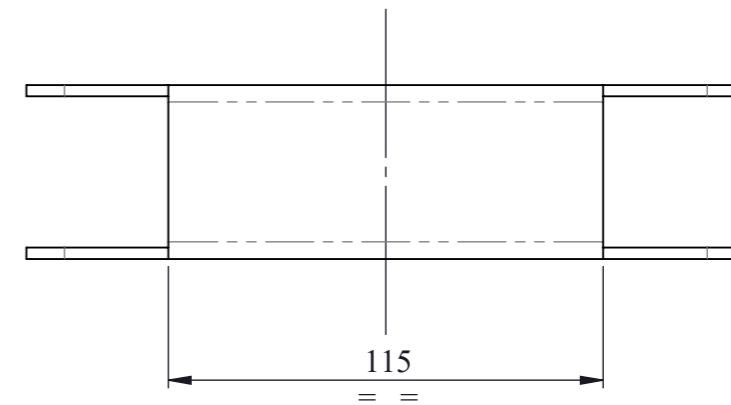
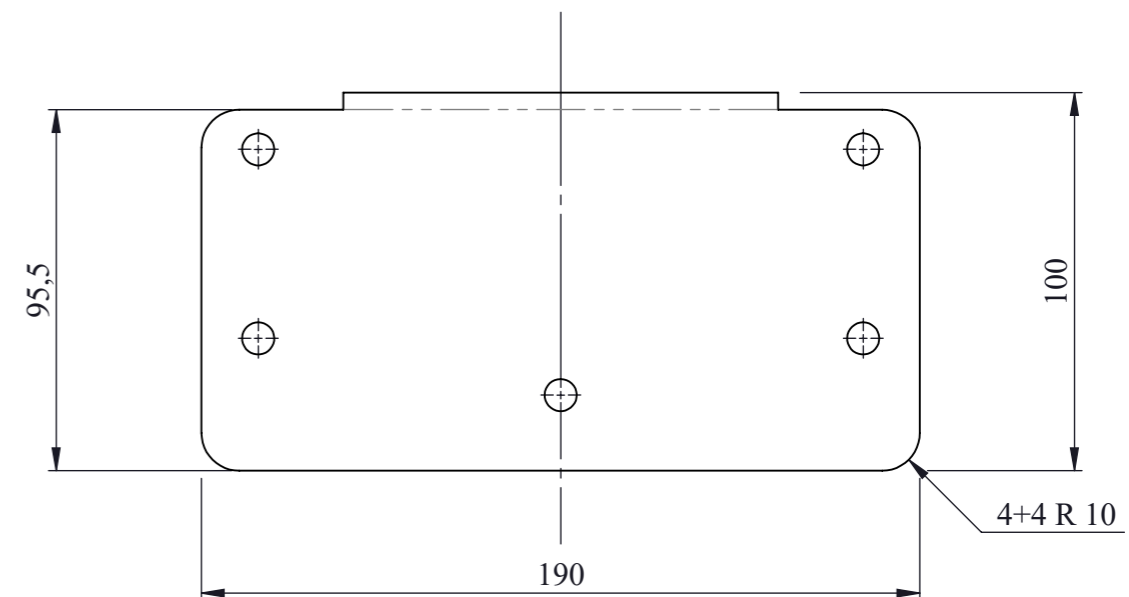
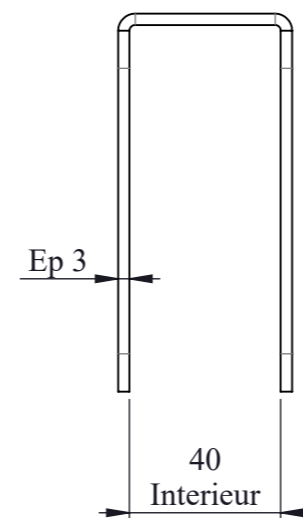
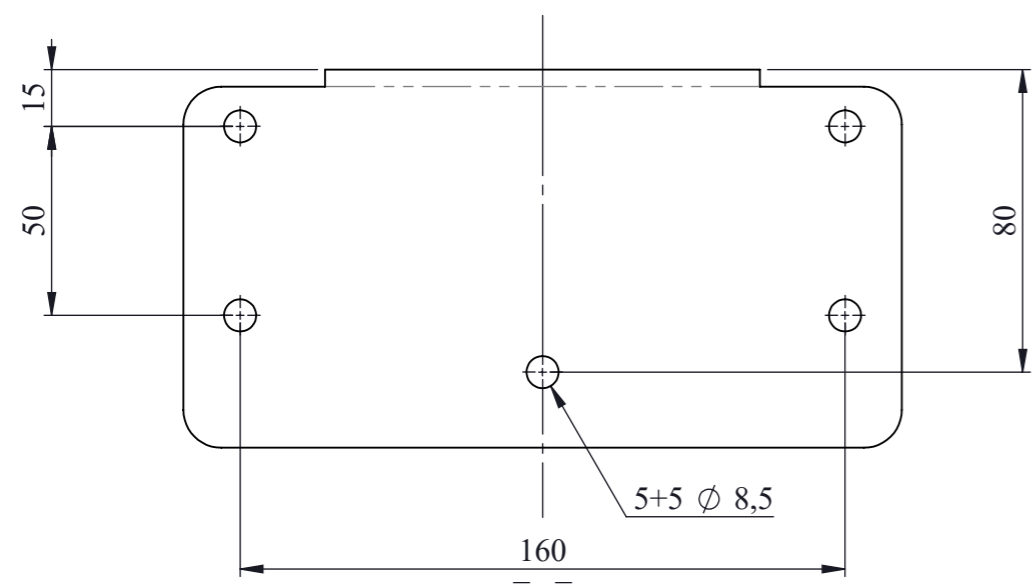

Qté: 1

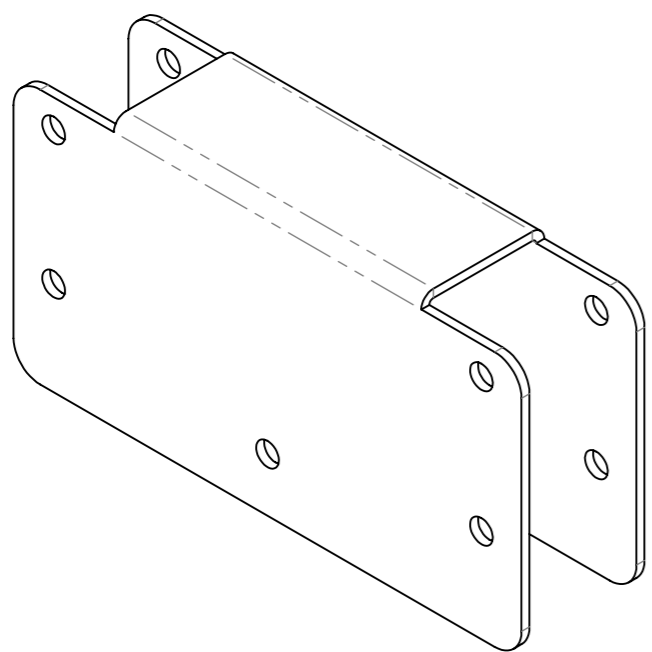

CE DOCUMENT EST LA PROPRIETE INDUSTRIELLE DE LA SOCIETE MS PIANOS. IL NE PEUT ETRE COMMUNIQUE OU REPRODUIT SANS AUTORISATION ECRITE

A	11/06/2024	M.SARRAZY		Edition Originale
Ind	Date	Dessiné par	Vérifié par	Description de la modification

NOTA: Casser les angles et coins vifs, ébavurage soigné - Break the angles and sharp corners				Tolérances Générales JS 13
MATIERE Inox 304 (1.4301) (X5CrNi18-10)				Rugosité
TRAITEMENT				Masse 956.82 Grammes
PROTECTION				Surface 85492.08 mm²

Platine de roue

PROJECTION	IMPRESSION	PLAN D'ORIGINE	ECHELLE	FORMAT	CODE ARTICLE	INDICE	FEUILLE
	11/06/2024	""	1:2	A3	C24-0013		1/1

8

7

6

5

4

3

2

1