

8 7 6 5 4 3 2 1

F
E
D
C
B
A

F
E
D
C
B
A

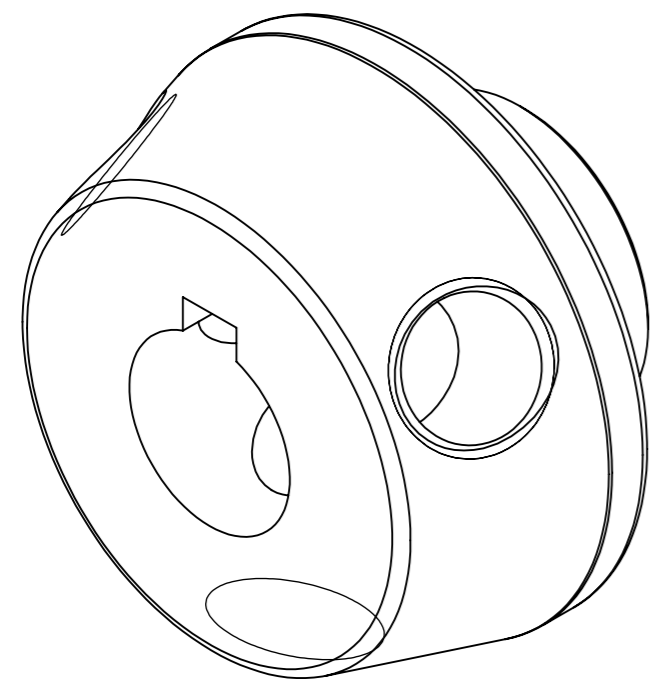
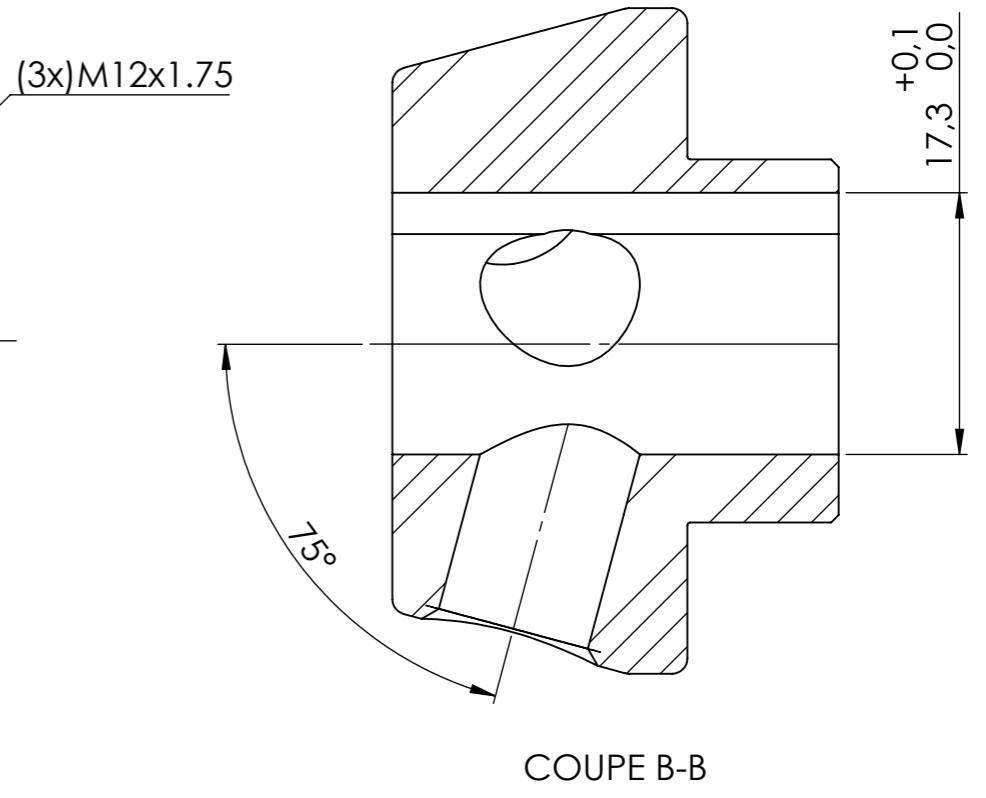
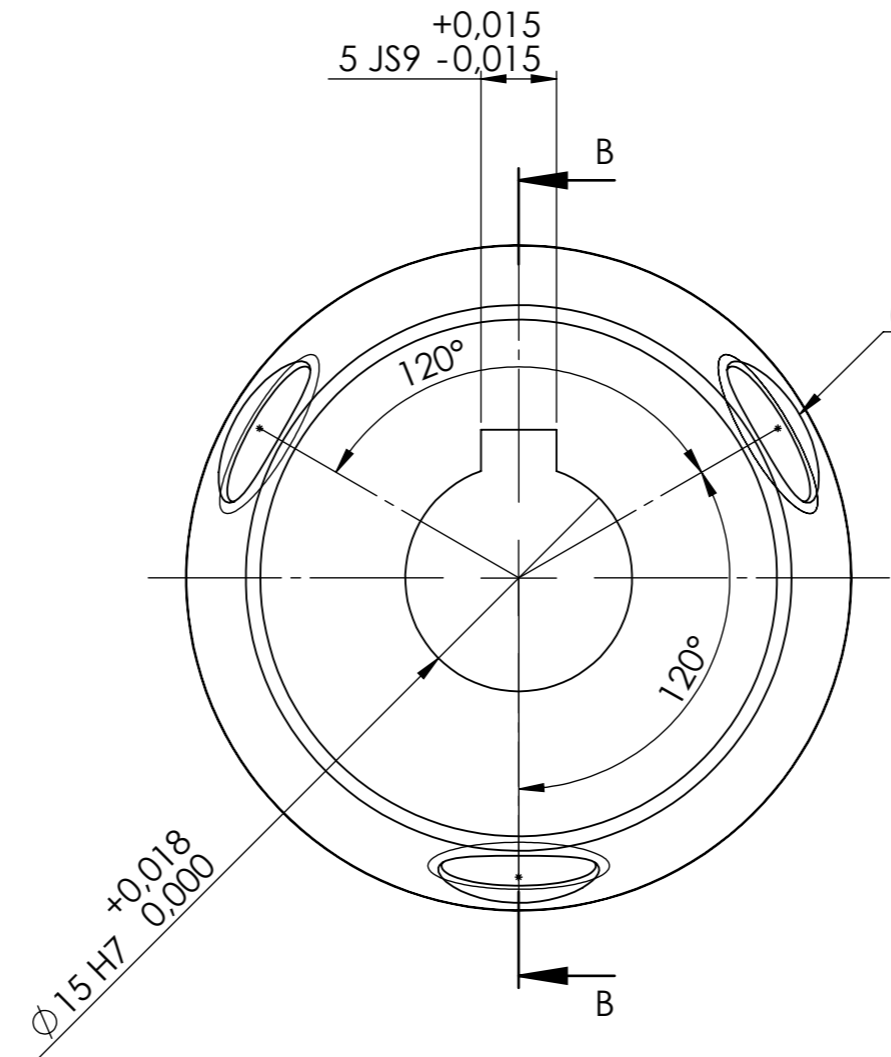
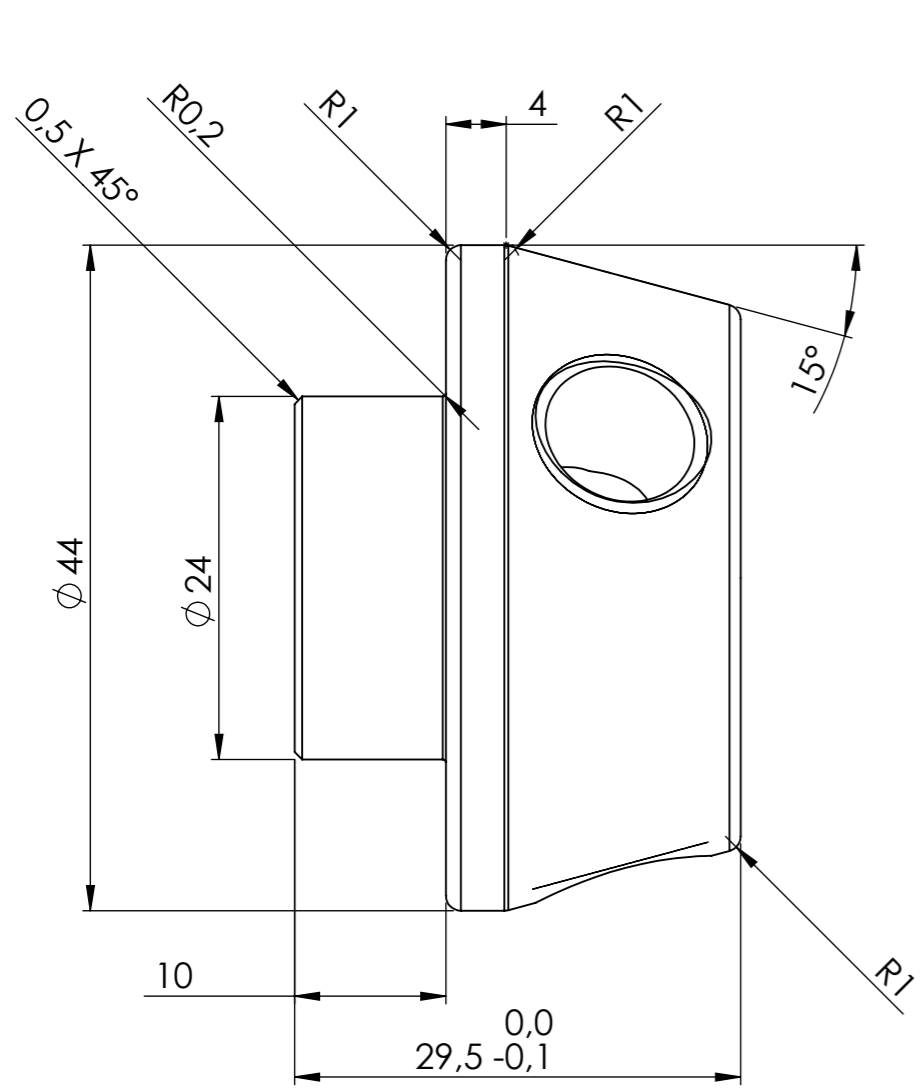

Weight		Material			
g		ACIER INOXYDABLE			
Machine		Description			
BROYEUR GROGGU		MOYEU VOLANT			
Projection method:		Release date	Drawing no.		Rev.
First angle		18/06/2024	GROG0115		A
General tolerances		Doc. type	Units unless specified	Sheet size	Scale
ISO 2768-m		Part	mm	A3	2:1
					Sheet
					1 / 1

8 7 6 5 4 3 2 1