

8 7 6 5 4 3 2 1

F  
E  
D  
C  
B  
A

F  
E  
D  
C  
B  
A

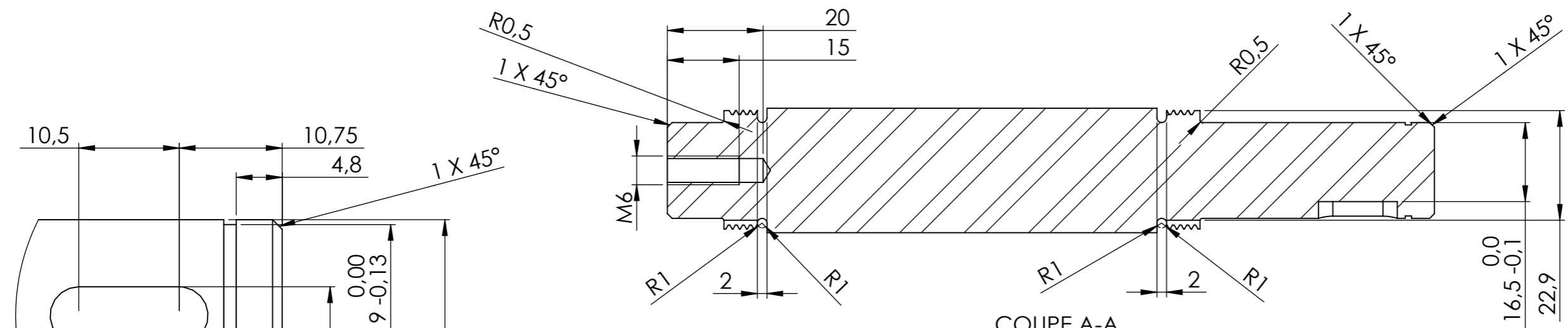

COUPE A-A

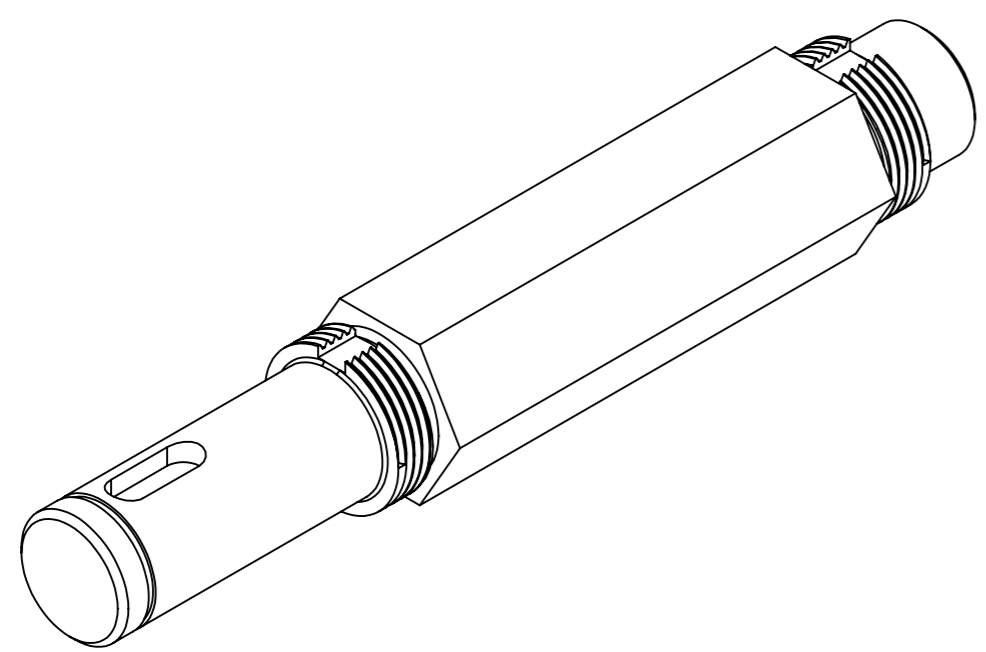
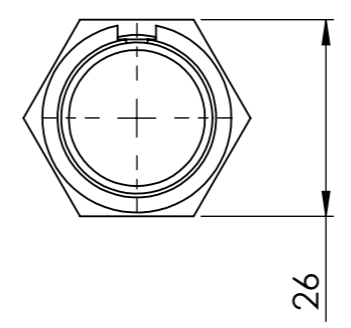
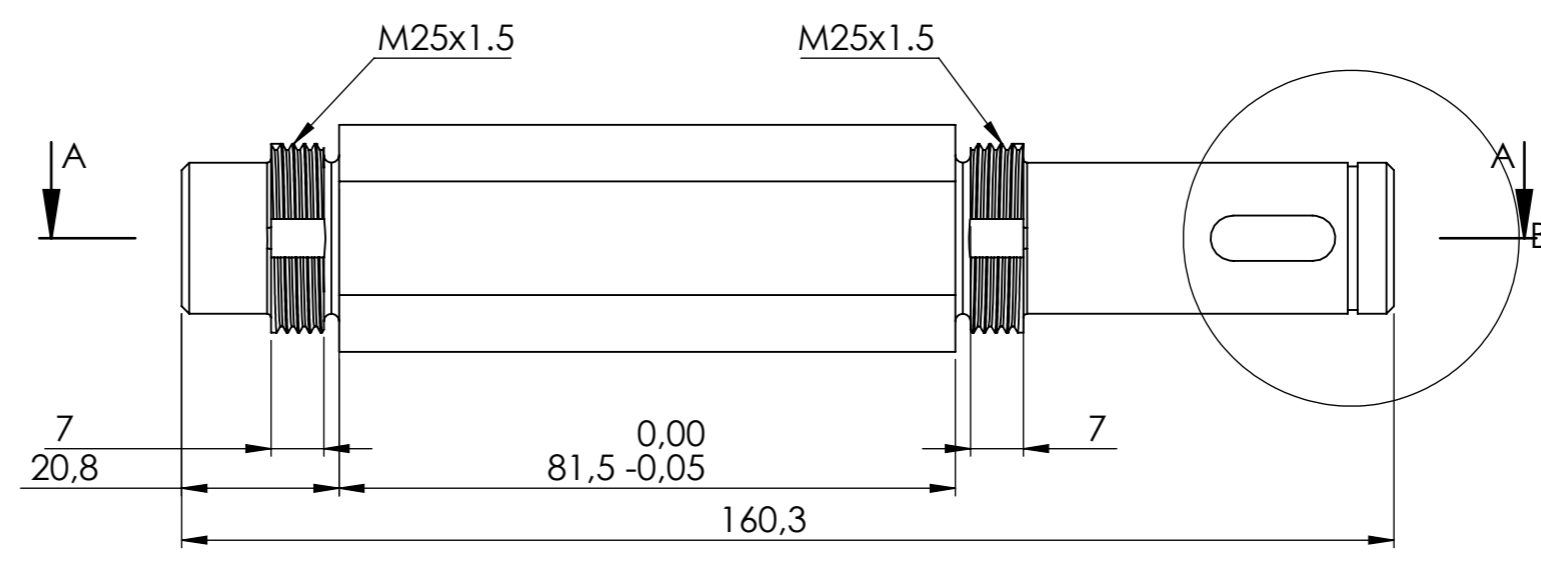
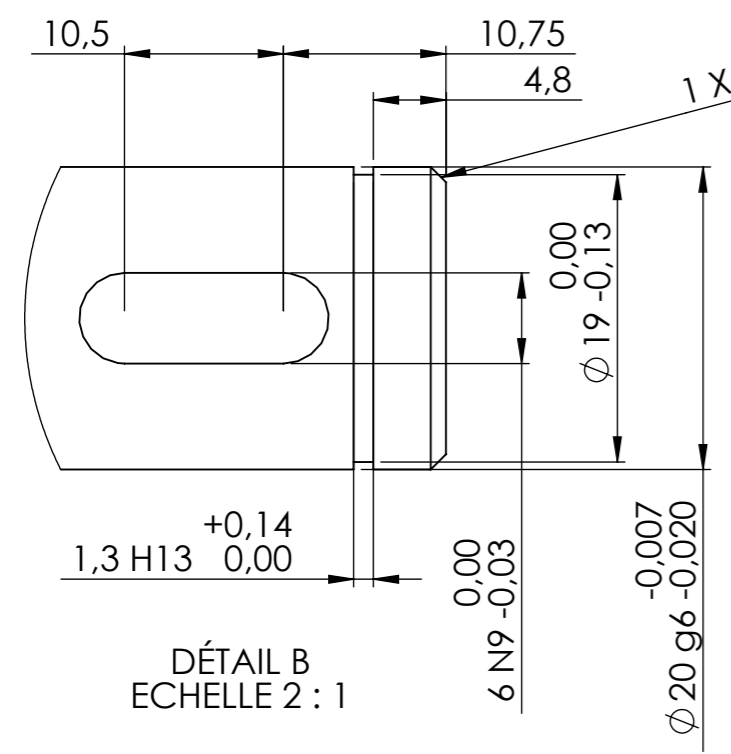

Weight		g		Material		ACIER C45		
Machine		BROYEUR GROGGU		Description				AXE BROYEUR D20
Projection method:		First angle		Release date		Drawing no.		Rev.
				18/06/2024		GROG01001		A
General tolerances		ISO 2768-m		Doc. type		Units unless specified		Sheet
				Part		mm		1 / 1
				Scale		Sheet size		Scale
				1:1		A3		1:1

8 7 6 5 4 3 2 1